

AC axial fan



- **Impeller material:** Sheet steel (welded to the rotor and stove-enameled in black)
- **Housing material:** Die-cast aluminum
- **Bearings:** Ball bearings

Nominal data

Type	Motor	Voltage 1 - VAC	Frequency Hz	Air flow m ³ /h	Speed 1/min	Power consumption W	Current draw A	Capacitor capacity uF/V	Sound pressure level dB(A)	Operative range 50Hz Pa	Weight kg
W2E200HK3801	M2E068BF	230	50	925	2550	64	0.29	1.5 / 400	59	0 .. 100	2.0

Subject to modification

Characteristic: Pressure over air flow at 50Hz

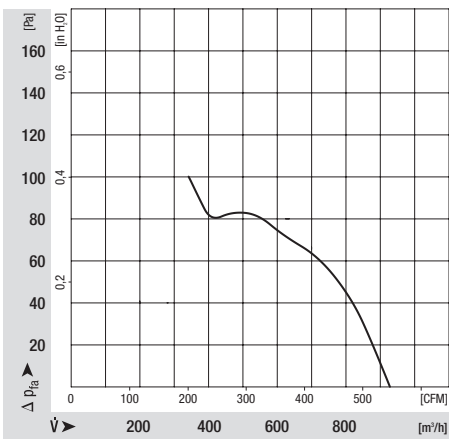

AC axial fan

Specific drawing

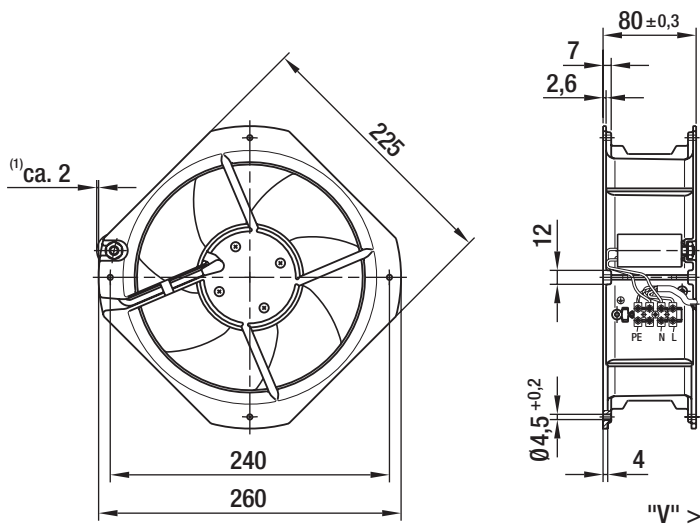

(1) Capacitor protrusion

Technical description

- **Impeller material:** Sheet steel (welded to the rotor and stove-enameled in black)
- **Bearings:** Ball bearings
- **Direction of flow:** "V", exhaust over braces
- **Operating mode:** S1
- **Protection class:** I
- **Approvals:** VDE, CSA, UL, CE
- **Housing material:** Die-cast aluminum
- **Direction of rotation:** Left, looking at rotor
- **Electrical connection:** Terminal strip (operating capacitor wired)
- **Insulation class:** "B"
- **Motor protection:** Built-in thermal overload protector

Contact

ebm-papst Mulfingen GmbH & Co. KG
Bachmühle 2
D-74673 Mulfingen
Phone +49 (0) 79 38 / 81-0
Fax +49 (0) 79 38 / 81-110
info1@de.ebmpapst.com
www.ebmpapst.com

Guard grille

Order No.

78128-2-4039

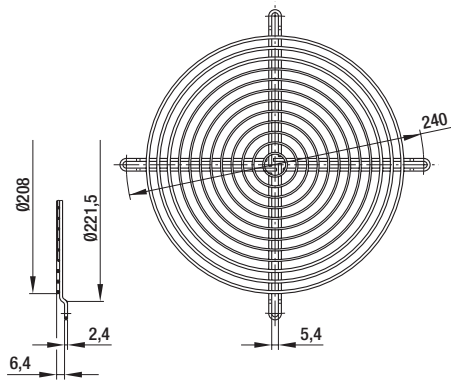

Technical description

- **Material:** Steel wire, plastic-coated, silver-metallic gloss

Contact

ebm-papst Mulfingen GmbH & Co. KG

Bachmühle 2

D-74673 Mulfingen

Phone +49 (0) 79 38 / 81-0

Fax +49 (0) 79 38 / 81-110

info1@de.ebmpapst.com

www.ebmpapst.com