

ebm-papst Mulfingen GmbH & Co. KG

Bachmühle 2 · D-74673 Mulfingen

Phone +49 7938 81-0

Fax +49 7938 81-110

info1@de.ebmpapst.com

www.ebmpapst.com

Limited partnership · Headquarters Mulfingen
County court Stuttgart · HRA 590344General partner Elektrobau Mulfingen GmbH · Headquarters Mulfingen
County court Stuttgart · HRB 590142**Nominal data**

Type	S4D630-CD01-01		
Motor	M4D138-LA		
Phase		3~	3~
Nominal voltage	VAC	400	400
Connection		Δ	Y
Frequency	Hz	50	50
Type of data definition		ml	ml
Valid for approval / standard		CE	CE
Speed	min ⁻¹	1320	1050
Power input	W	2630	1750
Current draw	A	4.78	2.95
Max. back pressure	Pa	220	140
Min. ambient temperature	°C	-40	-40
Max. ambient temperature	°C	60	60
Starting current	A	19	6.5

ml = max. load · me = max. efficiency · fa = running at free air · cs = customer specs · cu = customer unit
Subject to alterations

Data according to ErP directive

Installation category	A
Efficiency category	Static
Variable speed drive	No
Specific ratio*	1.00

* Specific ratio = $1 + p_{fs} / 100\,000\text{ Pa}$

	Actual	Request 2013	Request 2015
Overall efficiency η_{es}	32.8	32.1	36.1
Efficiency grade N	36.7	36	40
Power input P_e	kW	2.44	
Air flow q_v	m ³ /h	13365	
Pressure increase p_{fs}	Pa	217	
Speed n	min ⁻¹	1345	

Data established at point of optimum efficiency



AC axial fan - HyBlade®

sickled blades (S series)

with guard grille for full nozzle

Technical features

Mass	29.1 kg
Size	630 mm
Surface of rotor	Cast in aluminium
Material of terminal box	PP plastic
Material of blades	Aluminium sheet insert, sprayed with PP plastic
Material of guard grille	Steel, coated in black plastic (RAL9005)
Number of blades	5
Blade angle	0°
Direction of air flow	"V"
Direction of rotation	Clockwise, seen on rotor
Type of protection	IP 54
Insulation class	"F"
Humidity class	F3-1
Max. permissible ambient motor temp. (transp./ storage)	+ 80 °C
Min. permissible ambient motor temp. (transp./storage)	- 40 °C
Mounting position	Any
Condensate discharge holes	On rotor and stator sides
Operation mode	S1
Motor bearing	Ball bearing
Touch current acc. IEC 60990 (measuring network Fig. 4, TN system)	<= 3.5 mA
Electrical leads	Via terminal box
Motor protection	Thermal overload protector (TOP) brought out
Cable exit	Axial
Protection class	I (if protective earth is connected by customer)
Product conforming to standard	EN 60034; EN 61800-5-1; CE
Approval	GOST; VDE

AC axial fan - HyBlade®

sickled blades (S series)

with guard grille for full nozzle

Product drawing

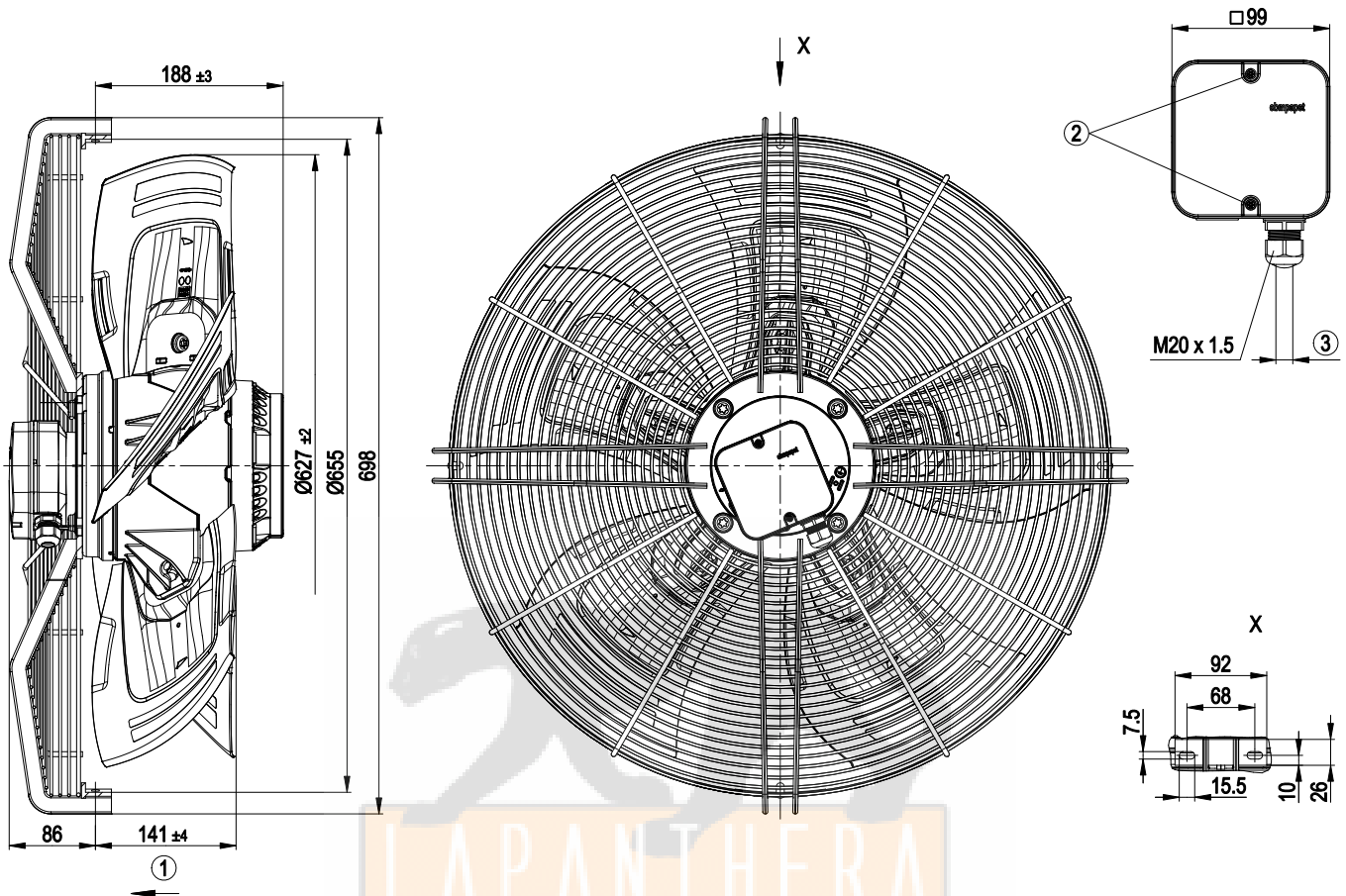

- | | |
|---|--|
| 1 | Direction of air flow "V" |
| 2 | Tightening torque 1.5±0.2 Nm |
| 3 | Cable diameter: min. 7 mm, max. 14 mm, tightening torque: 2±0.3 Nm |

AC axial fan - HyBlade®

sickled blades (S series)

with guard grille for full nozzle

Connection screen

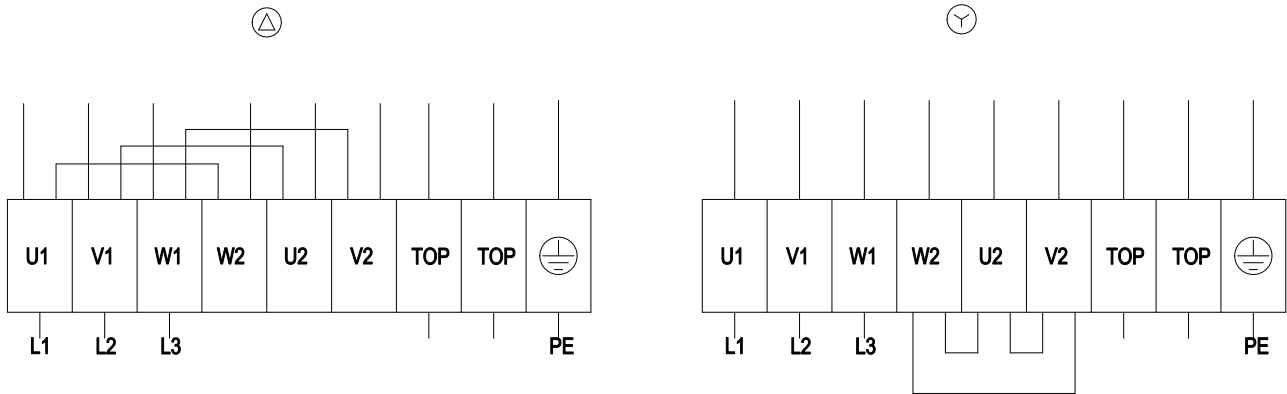

Δ	Delta connection	Y	Star connection	L1	= U1 = black
L2	= V1 = blue	L3	= W1 = brown	W2	yellow
U2	green	V2	white	TOP	2 x grey
PE	green/yellow				

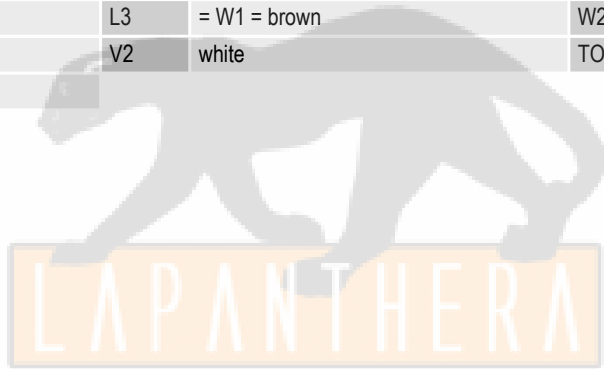

Charts: Air flow 50 Hz

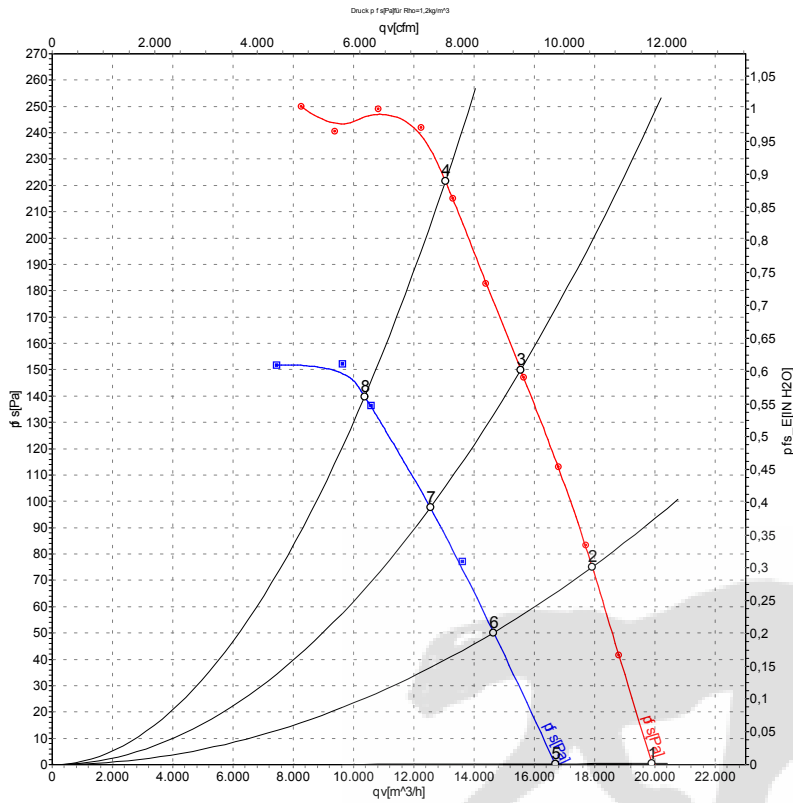

Measurement: LU-115597
Measurement: LU-115637

Air performance measured as per ISO 5801 Installation category A. For detailed information on the measuring set-up, please contact ebm-papst. Suction-side noise levels: LwA measured as per ISO 13347 / LpA measured with 1m distance to fan axis. The values given are valid under the measuring conditions mentioned above and may vary according to the actual installation situation. With any deviation from the standard set-up, the specific values have to be checked and reviewed with the unit installed.

Measured values

	Conn.	U	f	n	Pe	I	LpA _{in}	LwA _{in}	LwA _{out}	qv	p _{fs}
		V	Hz	min ⁻¹	W	A	dB(A)	dB(A)	dB(A)	m ³ /h	Pa
1	Δ	400	50	1375	2116	4.07	71	79	80	19890	0
2	Δ	400	50	1360	2299	4.29	71	78	79	17910	75
3	Δ	400	50	1345	2465	4.56	71	77	78	15540	150
4	Δ	400	50	1320	2630	4.78	73	80	80	13040	220
5	Y	400	50	1150	1536	2.58	66	74	75	16680	0
6	Y	400	50	1115	1615	2.71	65	72	73	14640	51
7	Y	400	50	1080	1684	2.83	65	72	73	12540	98
8	Y	400	50	1050	1750	2.95	67	74	73	10360	140

Conn. = Connection · U = Supply voltage · f = Frequency · n = Speed · P_e = Power input · I = Current draw · LpA_{in} = Sound pressure level inlet side · LwA_{in} = Sound power level inlet side
LwA_{out} = Sound power level outlet side · qv = Air flow · p_{fs} = Pressure increase

