

AC axial fan

S series



- **Design:** Basket guard grille
- **Impeller material:** Sheet steel, coated in black
- **Motor material:** Rotor: Coated in black

Nominal data		Voltage	Frequency	Air flow	Speed	Power consumption	Current draw	Capacitor capacity	Sound pressure level	Operative range 60Hz	Ambient temperature 60Hz	Weight
Type	Motor	1 - VAC	Hz	m ³ /h	1/min	W	A	uF/V	dB(A)	Pa	°C	kg
S2E300AP0231	M2E074DF	230	60	3740	3000	350	1.55	8.0 / 400	76	0..50	-25 .. 40	3.0

Subject to modification

Characteristic: Pressure over air flow at 60Hz

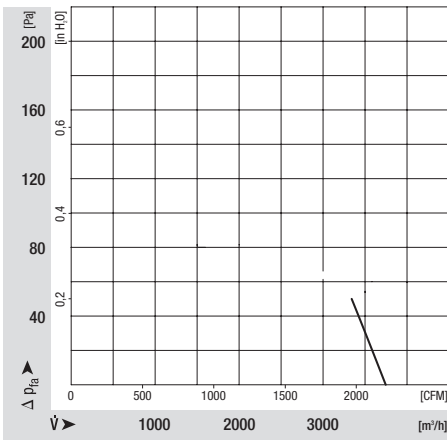

AC axial fan

S series

Specific drawing

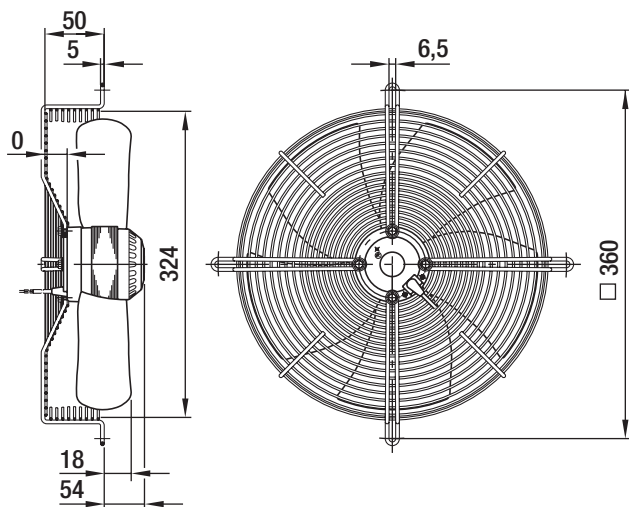

Connection illustration

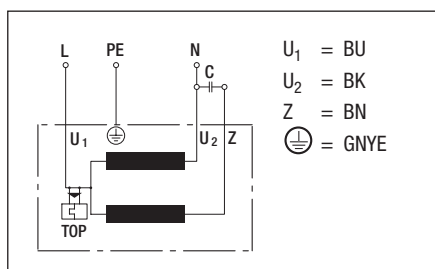

Technical description

- **Design:** Basket guard grille
- **Motor material:** Rotor: Coated in black
- **Direction of rotation:** Clockwise, seen on rotor
- **Number of impeller blades:** 5
- **Cable layout:** Variable
- **Guideline:** EN 60335-1, CE
- **Insulation class:** "B"
- **System of protection:** IP 44
- **Approvals:** CCC
- **Impeller material:** Sheet steel, coated in black
- **Bearings:** Maintenance-free ball bearings
- **Direction of flow:** "A"
- **Electrical connection:** Brass lead tips
- **Screw depth:** Max. 10 mm
- **Operating mode:** Continuous operation (S1)
- **Protection class:** I
- **Motor protection:** TOP wired internally

Contact

ebm-papst Mulfingen GmbH & Co. KG

Bachmühle 2

D-74673 Mulfingen

Phone +49 (0) 79 38 / 81-0

Fax +49 (0) 79 38 / 81-110

info1@de.ebmpapst.com

www.ebmpapst.com