

K3G097-BK36-56

EC dual centrifugal fan

forward-curved, dual-intake

with housing, Automotive

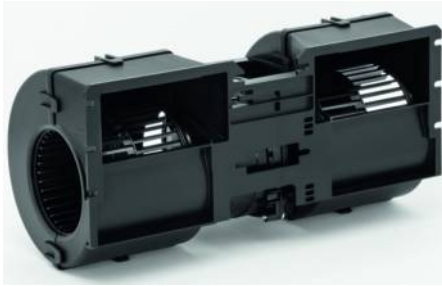

ebm-papst Mulfingen GmbH & Co. KG

Bachmühle 2 · D-74673 Mulfingen

Phone +49 7938 81-0

Fax +49 7938 81-110

info1@de.ebmpapst.com

www.ebmpapst.com

Limited partnership · Headquarters Mulfingen

Amtsgericht (court of registration) Stuttgart · HRA 590344

General partner Elektrobau Mulfingen GmbH · Headquarters Mulfingen

Amtsgericht (court of registration) Stuttgart · HRB 590142

Nominal data

Type	K3G097-BK36-56	
Motor	M3G074-CF	
Nominal voltage	VDC	13
Nominal voltage range	VDC	9 .. 15
Method of obtaining data		fa
Speed (rpm)	min ⁻¹	3970
Power consumption	W	356
Current draw	A	27.4
Min. ambient temperature	°C	-40
Max. ambient temperature	°C	70

ml = Max. load · me = Max. efficiency · fa = Free air · cs = Customer specification · ce = Customer equipment
Subject to change



Technical description

Weight	2.3 kg
Size	97 mm
Motor size	74
Impeller material	PA plastic
Housing material	PP plastic
Number of blades	34
Balancing grade according to DIN ISO 21940-11	G 2.5
Direction of rotation	Clockwise, viewed toward rotor
Degree of protection	Motor IP24 KM
Insulation class	"B"
Moisture (F) / Environmental (H) protection class	H1
Max. permitted ambient temp. for motor (transport/storage)	+70 °C
Min. permitted ambient temp. for motor (transport/storage)	-40 °C
Installation position	Any
Condensation drainage holes	None, open rotor
Cooling hole/opening	On rotor side
Mode	S1
Motor bearing	Ball bearing; (sealed)
Life expectancy	40,000 h (typical)
Technical features	<ul style="list-style-type: none"> - Fault output (open collector) - Power limiter - Load dump protection - Motor current limitation - Soft start - Control input 0-10 VDC / PWM - Thermal overload protection for electronics
Electrical hookup	Standby current less than 500 µA
Motor protection	Reverse polarity and locked-rotor protection
With cable	Variable
Protection class assignment	<p>III; Requires supply with safety extra-low voltage SELV.</p> <p>This component for installation may have several local protection classes. This information relates to this component's basic design.</p> <p>The final protection class is based on the component's intended installation and connection.</p>
Approval	EAC

EC dual centrifugal fan

forward-curved, dual-intake
with housing, Automotive

Product drawing

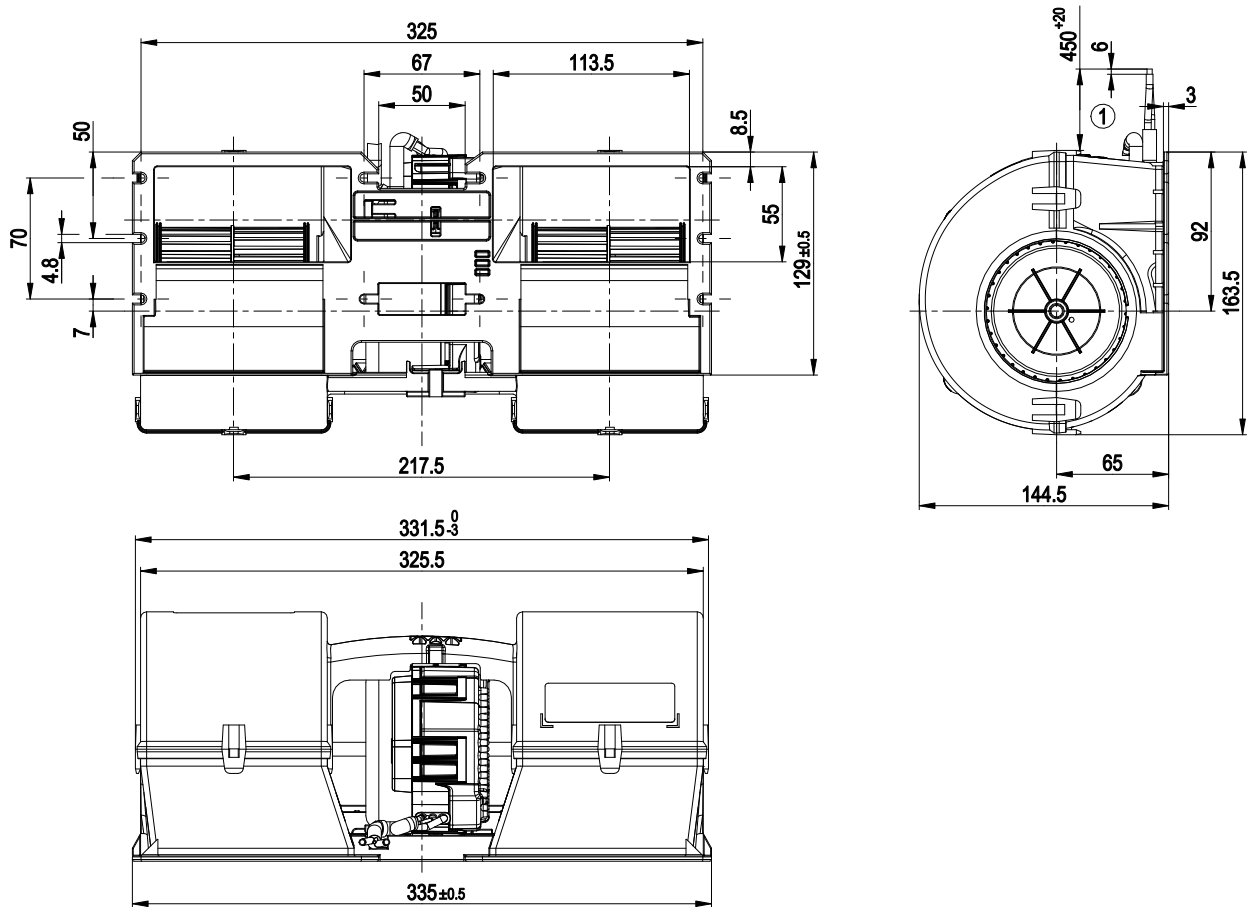

1	Cable FLRY 2x 4.0 mm ² , FLRY 1x 0.75 mm ² , 3x stripped and tin-plated wire ends
	+ UB (black)
	PWM/LIN (yellow)
	GND (brown)

EC dual centrifugal fan

forward-curved, dual-intake

with housing, Automotive

Connection diagram

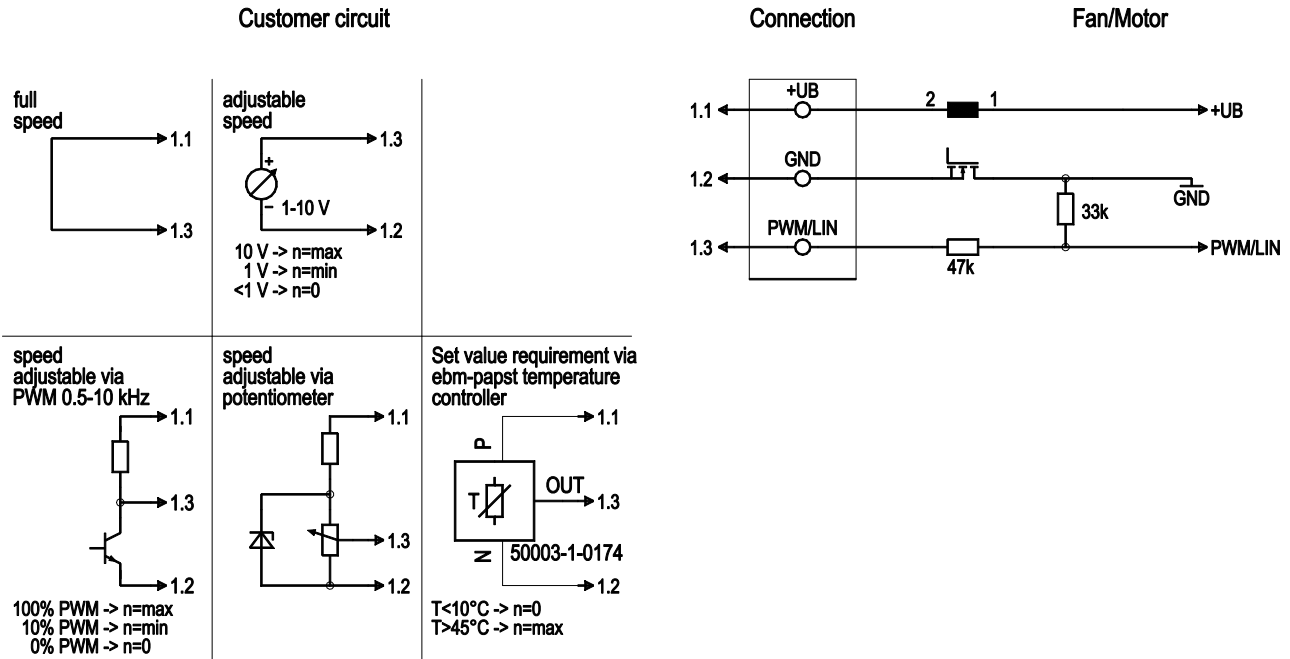

No.	Conn.	Designation	Color	Function/assignment
	1.1	+UB	black	Power supply
	1.2	GND	brown	Power supply GND, reference ground
	1.3	PWM/LIN	yellow	Control input Re > 100k



EC dual centrifugal fan

forward-curved, dual-intake

with housing, Automotive

Curves: Air performance

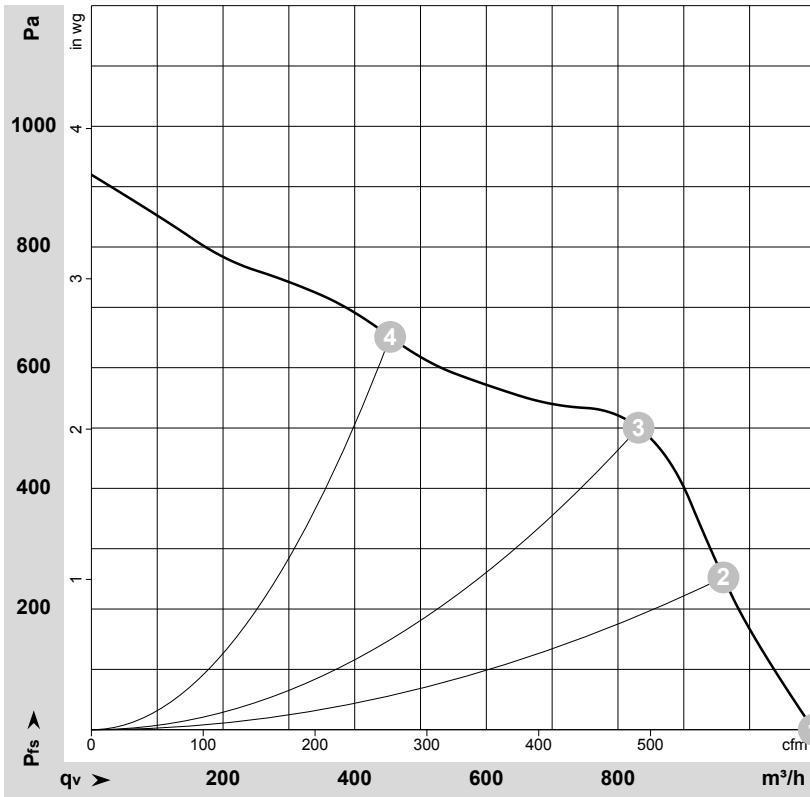

$\rho = 1.15 \text{ kg/m}^3 \pm 2 \%$

Measurement: LU-122518-1

Air performance measured according to ISO 5801 installation category A. For detailed information on the measurement setup, contact ebmpapst. Intake sound level: Sound power level according to ISO 13347 / sound pressure level measured at 1 m distance from fan axis. The values given are valid under the specified measuring conditions and may vary due to conditions of installation. For deviations from the standard configuration, the parameters have to be checked on the installed unit.

Measured values

	U	n	P _{ed}	I	LpA _{in}	LwA _{in}	q _v	P _{fs}	q _v	P _{fs}
	V	min ⁻¹	W	A	dB(A)	dB(A)	m ³ /h	Pa	cfm	in. wg
1	13	3970	356	27.40	69	80	1095	0	645	0.00
2	13	4250	343	26.26	69	80	960	250	565	1.00
3	13	4675	338	25.77	69	80	830	500	490	2.01
4	13	4960	250	19.20	70	81	455	650	265	2.61

U = Voltage · n = Speed (rpm) · P_{ed} = Power consumption · I = Current draw · LpA_{in} = Sound pressure level intake side · LwA_{in} = Sound power level intake side · q_v = Air flow
 P_{fs} = Pressure increase

