

K3G097-AK28-20

# EC dual centrifugal fan

forward-curved, with brushless DC motor  
with housing, Automotive



## ebm-papst Mulfingen GmbH & Co. KG

Bachmühle 2 · D-74673 Mulfingen

Phone +49 7938 81-0

Fax +49 7938 81-110

info1@de.ebmpapst.com

www.ebmpapst.com

Limited partnership · Headquarters Mulfingen

Amtsgericht (court of registration) Stuttgart · HRA 590344

General partner Elektrobau Mulfingen GmbH · Headquarters Mulfingen

Amtsgericht (court of registration) Stuttgart · HRB 590142

## Nominal data

Type	K3G097-AK28-20	
Motor	M3G074-CF	
Nominal voltage	VDC	26
Nominal voltage range	VDC	16 .. 32
Method of obtaining data		fa
Status		prelim.
Speed (rpm)	min <sup>-1</sup>	3500
Power consumption	W	345
Current draw	A	13.2
Min. back pressure	Pa	0
Min. back pressure	in. wg	0
Min. ambient temperature	°C	-40
Max. ambient temperature	°C	70

ml = Max. load · me = Max. efficiency · fa = Free air · cs = Customer specification · ce = Customer equipment  
Subject to change



# EC dual centrifugal fan

forward-curved, with brushless DC motor  
with housing, Automotive

## Technical description

<b>Weight</b>	2.18 kg
<b>Size</b>	97 mm
<b>Motor size</b>	74
<b>Impeller material</b>	PA plastic UL94 HB (black)
<b>Housing material</b>	PP plastic (black)
<b>Balancing grade according to DIN ISO 21940-11</b>	G 6.3
<b>Direction of rotation</b>	Clockwise, viewed toward rotor
<b>Degree of protection</b>	Motor IP24 KM
<b>Insulation class</b>	"B"
<b>Moisture (F) / Environmental (H) protection class</b>	H1
<b>Max. permitted ambient temp. for motor (transport/storage)</b>	+85 °C
<b>Min. permitted ambient temp. for motor (transport/storage)</b>	-40 °C
<b>Installation position</b>	Any
<b>Condensation drainage holes</b>	None, open rotor
<b>Cooling hole/opening</b>	On rotor side
<b>Mode</b>	S1
<b>Motor bearing</b>	Ball bearing; (sealed)
<b>Life expectancy</b>	40,000 h (typical)
<b>Technical features</b>	<ul style="list-style-type: none"> <li>- Locked-rotor detection</li> <li>- Power limiter</li> <li>- Load dump (58 V)</li> <li>- Motor current limitation</li> <li>- Soft start</li> <li>- Control input 0-10 VDC / PWM</li> <li>- Temperature derating</li> <li>- Overvoltage detection</li> <li>- Thermal overload protection for electronics</li> <li>- Line undervoltage detection</li> </ul>
<b>EMC regulations</b>	According to ECE R10 Rev.6
<b>Electrical hookup</b>	Plug; Standby current less than 500 µA
<b>Motor protection</b>	Passive reverse polarity and locked-rotor protection
<b>Protection class assignment</b>	<p>III; Requires supply with safety extra-low voltage SELV.</p> <p>This component for installation may have several local protection classes. This information relates to this component's basic design.</p> <p>The final protection class is based on the component's intended installation and connection.</p>
<b>Approval</b>	E1; EAC
<b>Comment</b>	Type approval number – 069362



# EC dual centrifugal fan

forward-curved, with brushless DC motor  
with housing, Automotive

## Product drawing

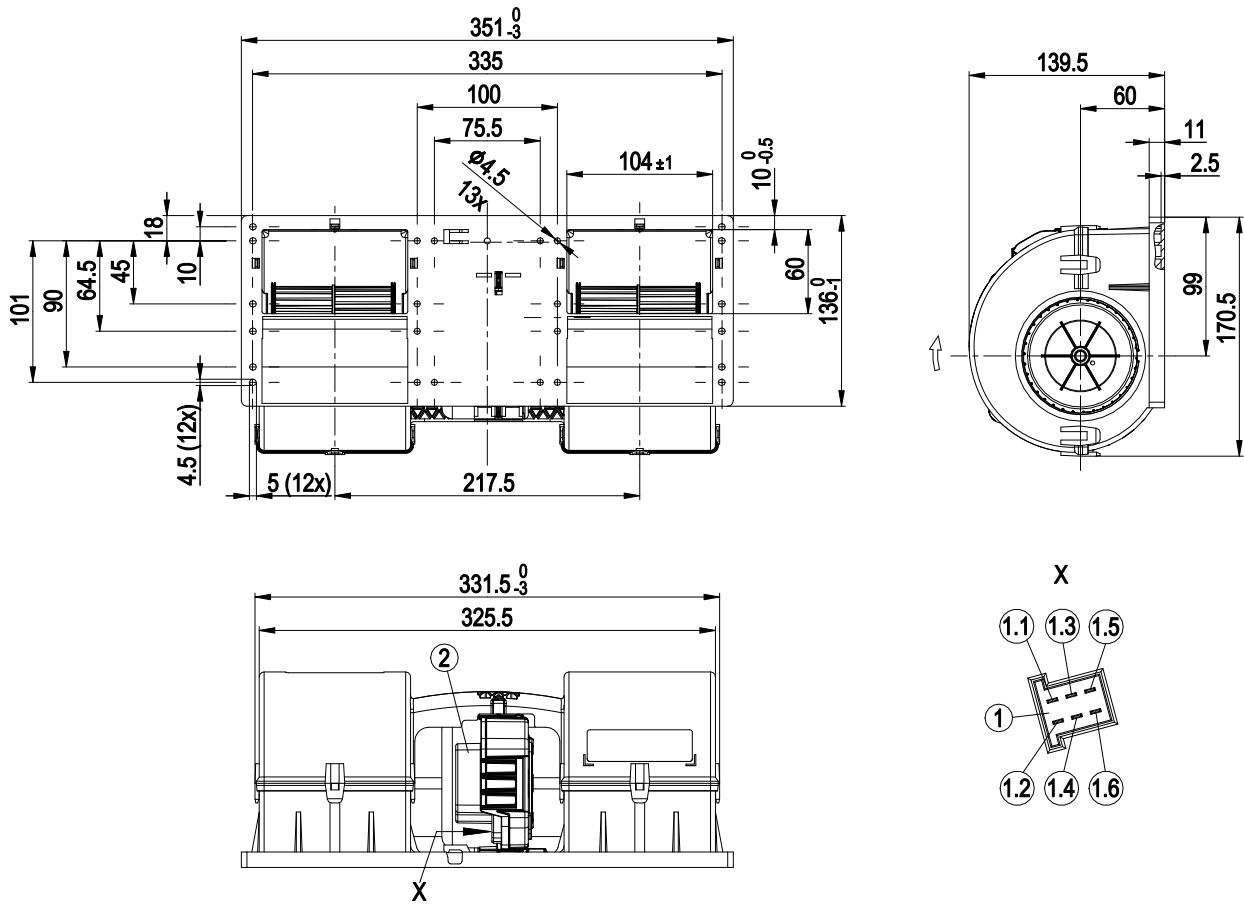

1	6-pole header TE Junior Power Timer WE_9901118
1.1	+ UB
1.2	GND
1.3	PWM/LIN, 100% speed
1.4	80% speed
1.5	60% speed
1.6	Not used / no function
	Accessory part: Cable (460 mm) with mating connector, part no. 02001-4-1021 not included in scope of delivery 6-pole mating connector TE 929504-2, 4x plug contact TE 927771-1, 2x plug contact TE 927768-1
2	Electronics cover blue (RAL 5015)



# EC dual centrifugal fan

forward-curved, with brushless DC motor  
with housing, Automotive

## Connection diagram

Customer circuit

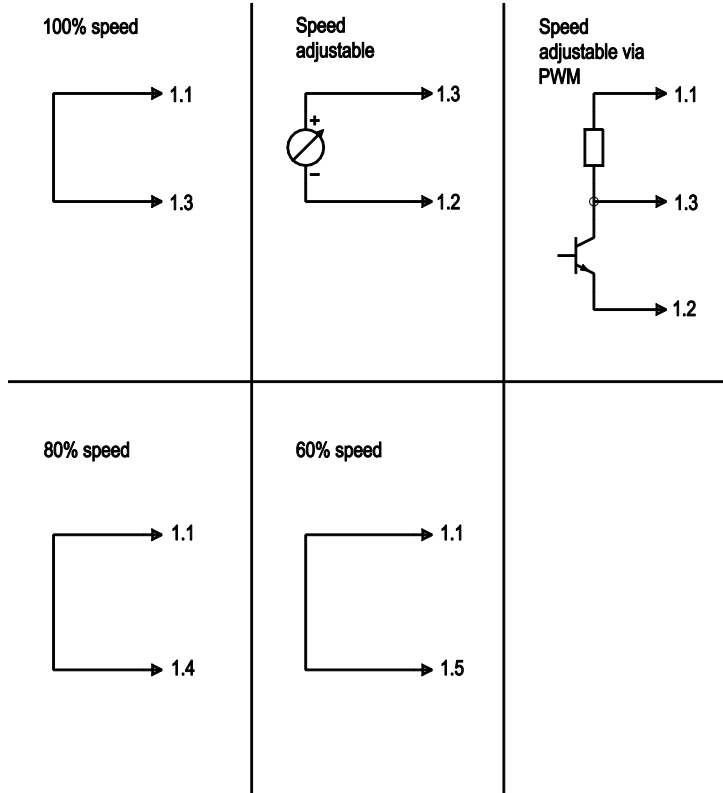

Connection

Fan/Motor

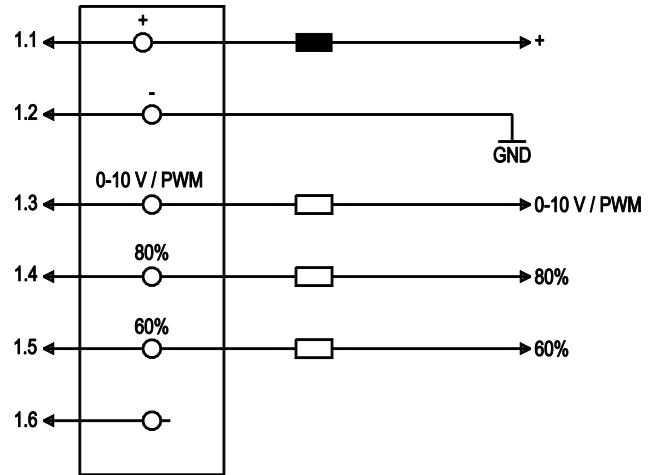

No.	Conn.	Designation	Function/assignment
	1.1	+	Power supply
	1.2	-	Power supply
	1.3	0-10 V / PWM	Control input: $R_i > 47\text{ k}\Omega$ 0-10 V (typ. $< 1\text{ V} \rightarrow n=0$ ; $1.2\text{ V} \rightarrow n=\text{min}$ ; $> 10\text{ V} \rightarrow n=\text{max}$ ) or PWM (amplitude = power supply; 10 kHz-50kHz)
	1.4	80%	Control input: $R_i > 47\text{ k}\Omega$ 80% speed level
	1.5	60%	Control input: $R_i > 47\text{ k}\Omega$ 60% speed level
	1.6		not used



# EC dual centrifugal fan

forward-curved, with brushless DC motor  
with housing, Automotive

## Curves: Air performance

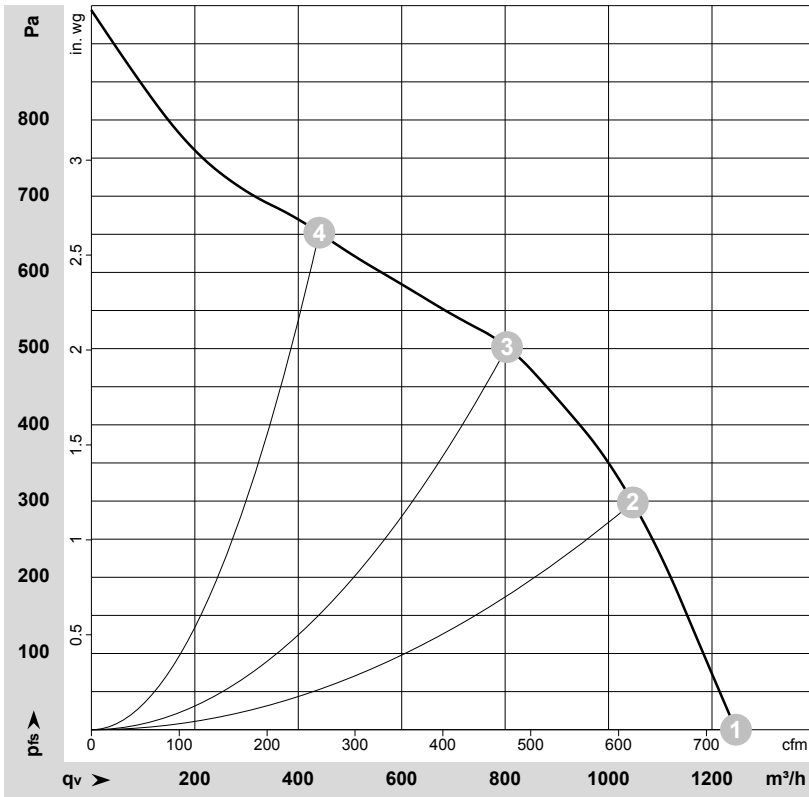

$\rho = 1.15 \text{ kg/m}^3 \pm 2 \%$

Measurement: LU-208001-1

Air performance measured according to ISO 5801 installation category A. For detailed information on the measurement setup, contact ebmpapst. Intake sound level: Sound power level according to ISO 13347 / sound pressure level measured at 1 m distance from fan axis. The values given are valid under the specified measuring conditions and may vary due to conditions of installation. For deviations from the standard configuration, the parameters have to be checked on the installed unit.

## Measured values

	U	n	P <sub>ed</sub>	I	LpA <sub>in</sub>	LwA <sub>in</sub>	q <sub>v</sub>	p <sub>fs</sub>	q <sub>v</sub>	p <sub>fs</sub>
	V	min <sup>-1</sup>	W	A	dB(A)	dB(A)	m <sup>3</sup> /h	Pa	cfm	in. wg
1	26	3500	345	13.20	70	81	1245	0	735	0.00
2	26	4095	336	12.93	68	78	1045	300	615	1.20
3	26	4420	275	10.55	67	77	805	500	475	2.01
4	26	4835	186	7.15	68	78	440	650	260	2.61

U = Voltage · n = Speed (rpm) · P<sub>ed</sub> = Power consumption · I = Current draw · LpA<sub>in</sub> = Sound pressure level intake side · LwA<sub>in</sub> = Sound power level intake side · q<sub>v</sub> = Air flow  
p<sub>fs</sub> = Pressure increase

