

# DC axial fan

Series 8400 N 80 x 80 x 25



- **General description:** DC fan with electronically commutated external rotor motor. Commutation electronics completely integrated.
- **Impeller material:** Fiberglass-reinforced PA plastic
- **Housing material:** Fiberglass-reinforced PBTP plastic

Nominal data		Voltage	Voltage range VDC	Air flow	Speed	Power consumption	Sound level	Sound pressure level	Ambient temperature	L10 service life at 40 °C	L10 service life at max. temp.	Weight
Type	Motor	VDC	VDC	m³/h	1/min	W	Bel	dB(A)	°C	h	h	kg
8412 NGL	--	12	8 - 15	33	1500	0.5	3.5	12	-20 .. 85	80000	27500	0.095

Subject to modification

## Characteristic: Pressure over air flow

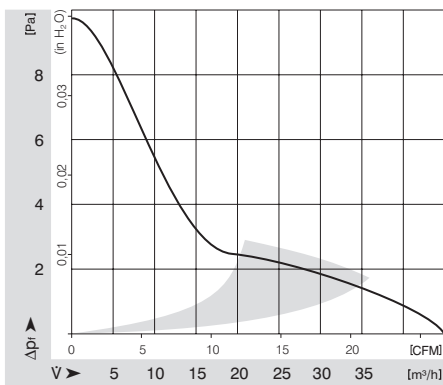

# DC axial fan

Series 8400 N 80 x 80 x 25

## Specific drawing

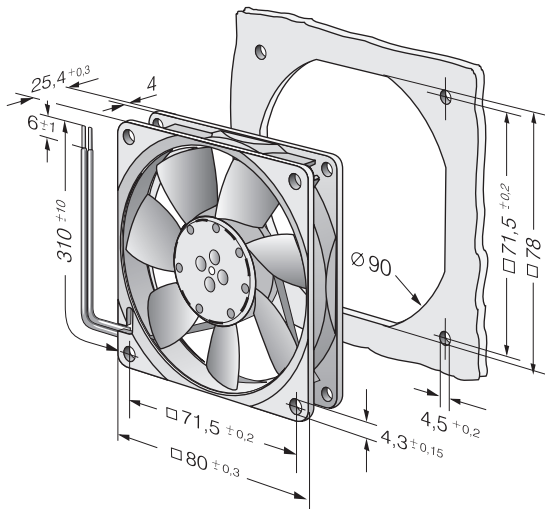

## Technical description

- **General description:** DC fan with electronically commutated external rotor motor. Commutation electronics completely integrated.
- **Housing material:** Fiberglass-reinforced PBTP plastic
- **Direction of rotation:** Left, looking at rotor
- **Electrical connection:** Single strands AWG 24, TR 64
- **Locked-rotor protection:** Locked-rotor and overload protection
- **Option:** Speed signal, Vario-Pro
- **Impeller material:** Fiberglass-reinforced PA plastic
- **Bearings:** Sintec sleeve bearing system
- **Direction of air flow:** Air exhaust over bars
- **Motor protection:** Reverse-polarity protected. The fan runs only if the polarity is correct.
- **Approvals:** VDE, CSA, UL, CE

## Contact

ebm-papst St. Georgen GmbH & Co. KG

Hermann-Papst-Straße 1

D-78112 St. Georgen

Phone +49 (0) 7724 / 81-0

Fax +49 (0) 7724 / 81-1309

info2@de.ebmpapst.com

www.ebmpapst.com

# Guard grille

Order No.

LZ32-4

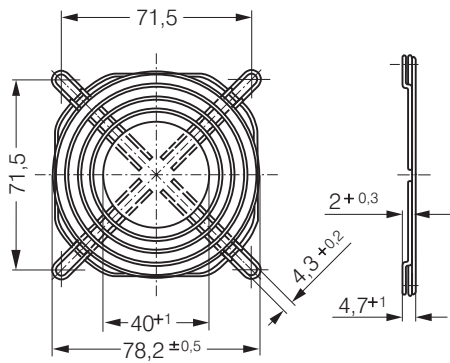

## Technical description

- **General description:** Guard grille in accordance with EN 294

- **Material:** Rust-protected steel wire

## Contact

**ebm-papst St. Georgen GmbH & Co. KG**

Hermann-Papst-Straße 1

D-78112 St. Georgen

Phone +49 (0) 7724 / 81-0

Fax +49 (0) 7724 / 81-1309

info2@de.ebmpapst.com

www.ebmpapst.com

# Guard grille

Order No.

LZ32-2

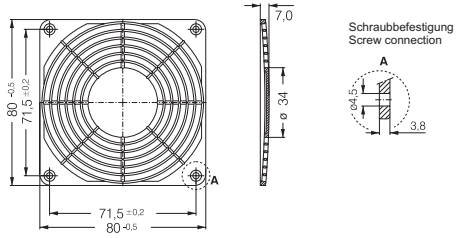

## Technical description

- **General description:** Guard grille in accordance with EN 294

- **Material:** Fiberglass-reinforced plastic

## Contact

**ebm-papst St. Georgen GmbH & Co. KG**

Hermann-Papst-Straße 1

D-78112 St. Georgen

Phone +49 (0) 7724 / 81-0

Fax +49 (0) 7724 / 81-1309

info2@de.ebmpapst.com

www.ebmpapst.com

# Guard grille

Order No.

LZ32-3

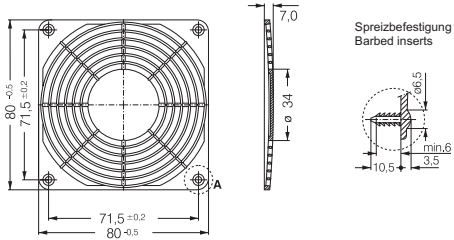

## Technical description

- **General description:** Guard grille in accordance with EN 294

- **Material:** Fiberglass-reinforced plastic

## Contact

ebm-papst St. Georgen GmbH & Co. KG  
Hermann-Papst-Straße 1  
D-78112 St. Georgen  
Phone +49 (0) 7724 / 81-0  
Fax +49 (0) 7724 / 81-1309  
info2@de.ebmpapst.com  
www.ebmpapst.com

# Spacer

Order No.

LZ261

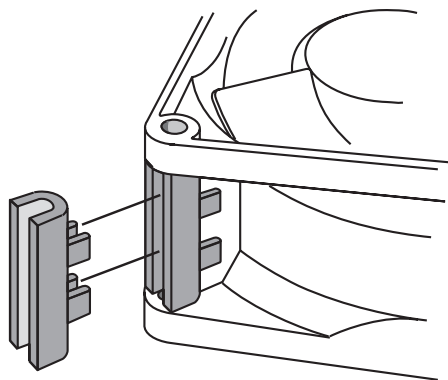

## Technical description

- **General description:** For mounting with screws using both ventilation mounting flanges
- **Note:** In addition to the accessories and mounting parts listed here, ebm-papst supplies a wide variety of other resources for fan operation, some of which are very specialized. The sales experts at ebm-papst will be happy to assist you in your inquiries concerning fan assembly and application.
- **Material:** Fiberglass-reinforced plastic

## Contact

### ebm-papst St. Georgen GmbH & Co. KG

Hermann-Papst-Straße 1  
D-78112 St. Georgen  
Phone +49 (0) 7724 / 81-0  
Fax +49 (0) 7724 / 81-1309  
info2@de.ebmpapst.com  
www.ebmpapst.com