

DC axial fan

Series 700 F 70 x 70 x 15



- **General description:** DC fan with electronically commutated external rotor motor. Commutation electronics completely integrated.

- **Impeller material:** Fiberglass-reinforced PA plastic

- **Housing material:** Fiberglass-reinforced PBT plastic

Nominal data		Voltage	Voltage range VDC	Air flow	Speed	Power consumption	Sound level	Sound pressure level	Ambient temperature	L10 service life at 40 °C	L10 service life at max. temp.	Weight
Type	Motor	VDC	VDC	m³/h	1/min	W	Bel	dB(A)	°C	h	h	kg
712 F/2L	--	12	8 - 13.8	28	3300	0.6	4.7	25	-20 .. 70	60000	30000	0.053

Subject to modification

Characteristic: Pressure over air flow

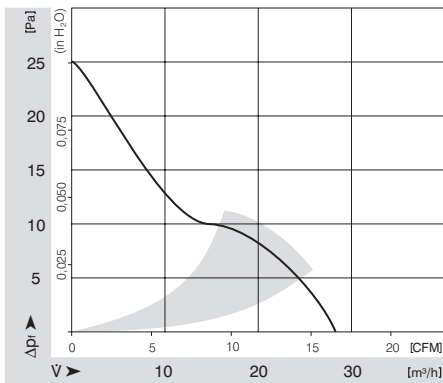

DC axial fan

Series 700 F 70 x 70 x 15

Specific drawing

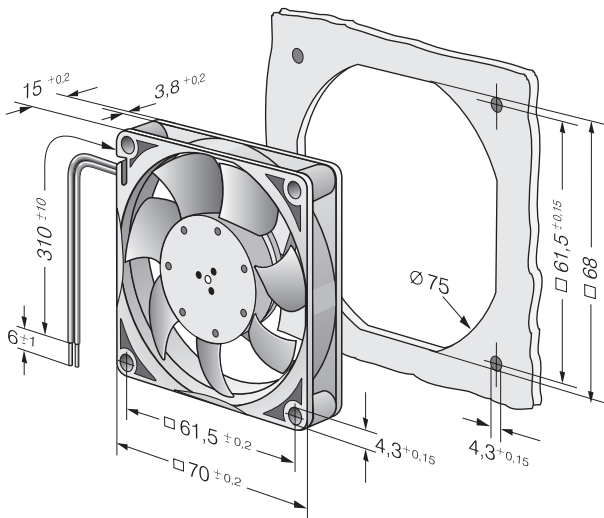

Technical description

- **General description:** DC fan with electronically commutated external rotor motor. Commutation electronics completely integrated.
- **Housing material:** Fiberglass-reinforced PBT plastic
- **Direction of rotation:** Left, looking at rotor
- **Electrical connection:** 3 single strands AWG 24, TR 64
- **Locked-rotor protection:** Locked-rotor and overload protection
- **Option:** Speed signal
- **Impeller material:** Fiberglass-reinforced PA plastic
- **Bearings:** Sintec sleeve bearing system
- **Direction of air flow:** Air exhaust over bars
- **Motor protection:** With electronic reverse polarity protection. The fan runs only if the polarity is correct.
- **Approvals:** VDE, CSA, UL, CE

Contact

ebm-papst St. Georgen GmbH & Co. KG
Hermann-Papst-Straße 1
D-78112 St. Georgen
Phone +49 (0) 7724 / 81-0
Fax +49 (0) 7724 / 81-1309
info2@de.ebmpapst.com
www.ebmpapst.com