

## 614F/2 DC axial fan

Very compact DC fan, 15 mm flat with outstanding air performance values at very little noise. DC fan with electronically commutated external rotor motor and fully integrated commutation electronics.



### Features

- Electronic protection against reverse polarity, locking and overloading.
- Air exhaust over struts. Rotational direction CCW looking at rotor.
- Very low EMI.
- Electrical connection via 3 leads AWG 28, TR 64. Stripped and tinned ends.
- Speed-proportional rectangular pulse output for external speed monitoring of fan motor.

### Technical data

Nominal Voltage	V DC	24
Voltage Range	V DC	21,6 ... 26,4
Nominal speed	min <sup>-1</sup>	3900
Maximum air flow	m <sup>3</sup> /h	29
Maximum air flow	CFM	17,1
Noise free air	dB(A)	27
Current consumption	mA	45
Power consumption	W	1,1
Maximum ambient temperature at maximum Voltage	°C	-20 ... +70
Service life (60 °C)	h	20.000
Service life (20 °C)	h	50.000
Approvals		UL, CSA, VDE
Fan housing / impeller		PBTP / PA 6.6
Bearing system		Sleeve bearing
Mass	g	30

All data are average values at nominal voltage

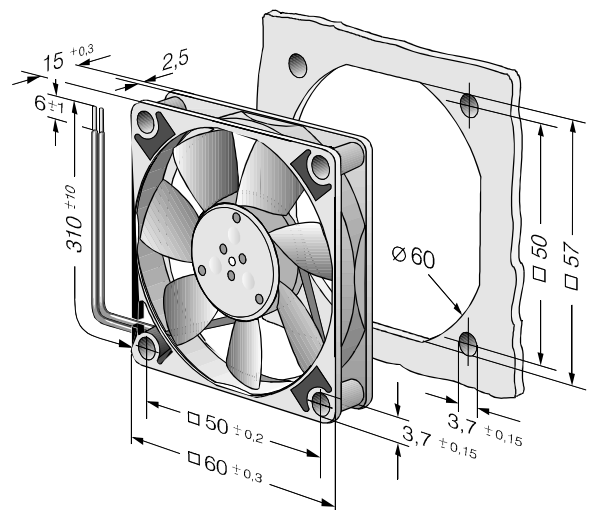
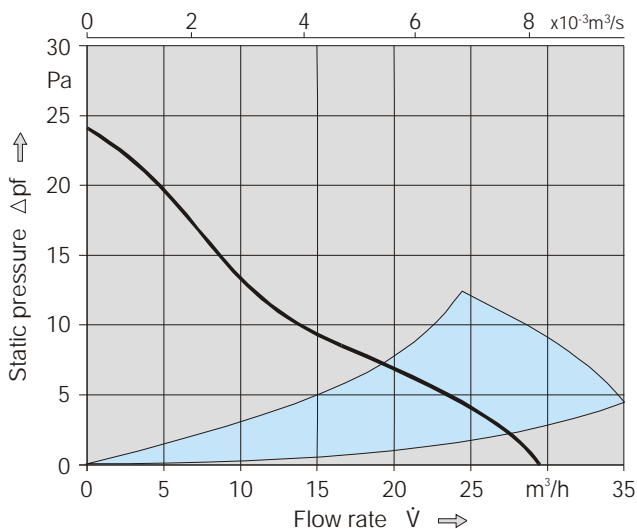

## Tacho output signal

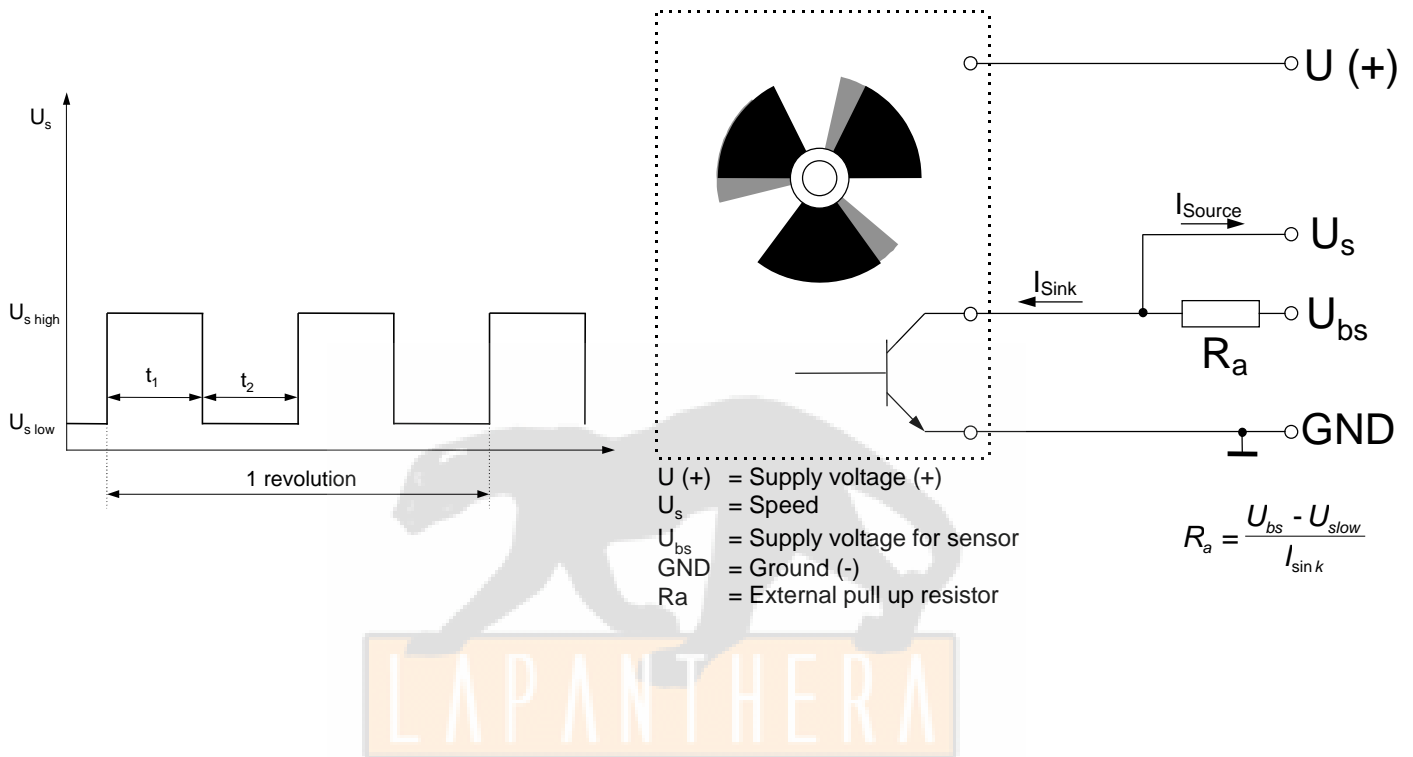

Output	2 pulses per revolution
$U_{bs}$	4...30 V DC
$U_{s\ high}$	4...30 V DC @ $I_{source} = 0\ mA$
$U_{s\ low}$	= 0,4 V DC @ $I_{sink} = 2\ mA$
$I_{sink\ max}$	= 4 mA
$t_1 / t_2$	0,8 - 1,2