

AC axial fan

S series



- **Design:** Basket guard grille
- **Impeller material:** Sheet steel, coated in black
- **Motor material:** Rotor: Coated in black

Nominal data		Voltage	Frequency	Air flow	Speed	Power consumption	Current draw	Sound pressure level	Operative range 50Hz	Ambient temperature 50Hz	Weight
Type	Motor	3 - VAC	Hz	m ³ /h	1/min	W	A	dB(A)	Pa	°C	kg
S2D250AI0201	M2D068CF	230/400	50	1830	2500	100	0.20	69	0..150	-25..65	2.1

Subject to modification Current draw at 230 VAC higher by a factor of 1.73

Characteristic: Pressure over air flow at 50Hz

n	P ₁	I	LpA	ntL
[1/min]	[W]	[A]	[dBA]	[%]

1	2455	106	0,2	--	--
2	2310	125	0,22	--	--

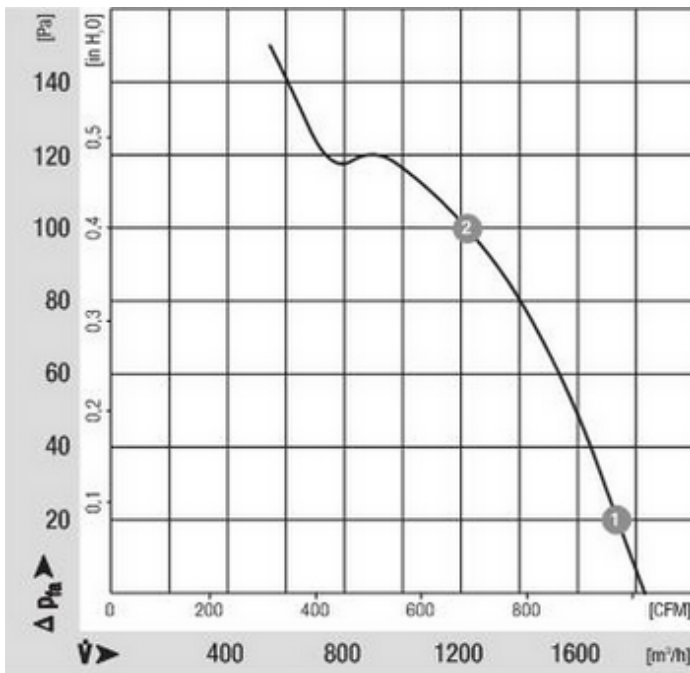

AC axial fan

S series

Specific drawing

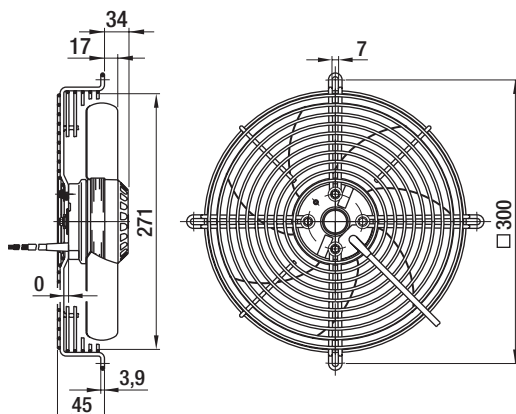

Connection illustration

Delta (3~ 230 VAC)

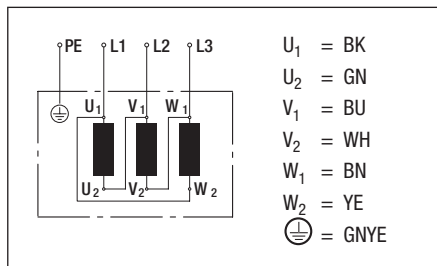

Star (3~ 400 VAC)

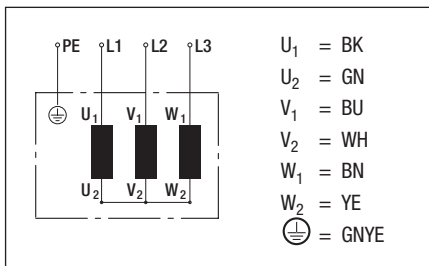

Technical description

- **Design:** Basket guard grille
- **Motor material:** Rotor: Coated in black
- **Direction of rotation:** Counter-clockwise, seen on rotor
- **Number of impeller blades:** 7
- **Cable layout:** On the side
- **Guideline:** EN 60335-1
- **Insulation class:** "B"
- **System of protection:** IP 44
- **Approvals:** CCC
- **Impeller material:** Sheet steel, coated in black
- **Bearings:** Maintenance-free ball bearings
- **Direction of flow:** "A"
- **Electrical connection:** Brass lead tips
- **Screw depth:** Max. 5 mm
- **Operating mode:** Continuous operation (S1)
- **Protection class:** I
- **Motor protection:** Without thermal protection

Contact

ebm-papst Mulfingen GmbH & Co. KG

Bachmühle 2

D-74673 Mulfingen

Phone +49 (0) 79 38 / 81-0

Fax +49 (0) 79 38 / 81-110

info1@de.ebmpapst.com

www.ebmpapst.com

Terminal box

Order No.

64444-1-7612

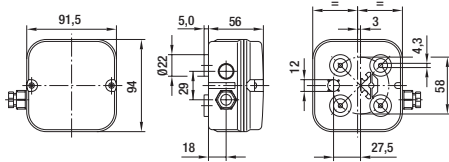

Technical description

- **General description:** 2-part terminal box for AC motors of size 068, with 7-pole terminal strip. Suitable for installation of a capacitor up to max. 10 μ F.

- **System of protection:** IP 54

- **Material:** ABS

Contact

ebm-papst Mulfingen GmbH & Co. KG

Bachmühle 2

D-74673 Mulfingen

Phone +49 (0) 79 38 / 81-0

Fax +49 (0) 79 38 / 81-110

info1@de.ebmpapst.com

www.ebmpapst.com